

## QSFP28 100G Duplex 30km ER4 LC Optical Transceiver

### TQ13L2E-CN Product Specification

#### FEATURES

- Hot-pluggable QSFP28 form factor
- Supports 103.125Gb/s aggregate bit rates
- Low power dissipation <5W
- Commercial case temperature range of 0°C to 70°C
- Maximum link length of 30km on SMF without FEC
- Maximum link length of 40km on SMF with FEC
- 4 channels LAN-WDM arrays and 4 channels APD arrays
- DDM function implemented
- Duplex LC receptacle
- Single 3.3V power supply
- RoHS compliant (lead free)

#### APPLICATIONS

- 100GBASE-ER4 100G Ethernet

#### ORDERING INFORMATION

Part Number	Form Factor	Data Rate (Gbps)	Media	Distance (km)	Wavelength (nm)	Temperature (°C)
TQ13L2E-CN	QSFP28	103.125	SMF	30	LWDM4	0~70

## 1. ABSOLUTE MAXIMUM RATINGS

Exceeding the limits below may damage the transceiver permanently.

Parameter	Symbol	Min	Typ	Max	Unit.	Note
Storage Temperature	TSTG	-40	-	85	°C	
Operating Relative Humidity	RH	5	-	95	%	
Supply Voltage	VCC	-0.3	-	3.6	V	

## 2. RECOMMENDED OPERATING CONDITIONS

Parameter	Symbol	Min	Typ	Max	Unit.	Note
Operating Case Temperature	Tc	0	-	70	°C	
Supply Voltage	VCC3	3.13	3.3	3.47	V	
Supply Current	ICC3	-	-	1500	mA	+3.3V Supply
Data rate per lane	DR	-	25.78125	-	GBd	

## 3. ELECTRICAL and OPTICAL CHARACTERISTICS

Parameter	Symbol	Min	Typ	Max	Unit.	Note
<b>Transmitter</b>						
Tx Differential Input Amplitude	Vin p-p	180	-	1000	mV	
Input Differential Impedance	Zin	90	100	110	Ω	
Center Wavelength Range	L0	1294.53	-	1296.59	nm	
	L1	1299.02	-	1301.09	nm	
	L2	1303.54	-	1305.63	nm	
	L3	1308.09	-	1310.19	nm	
Side-Mode Suppression Ratio	SMSR	30	-	-	dB	
Average Launch power, each lane	Pavg	-2.5	-	6.5	dBm	
Outer Optical Modulation Amplitude, each lane	Poma	0.1	-	4.5	dBm	
Launch power in OMA minus TDP		-0.65	-	-	dBm	
Transmitter and Dispersion Penalty (TDP)	TDP	-	-	2.5	dB	
Extinction ratio, each lane	ER	4.5	-	-	dB	
Relative Intensity Noise	RIN	-	-	-130	dB/Hz	
Optical Return Loss Tolerance	Tol	-	-	20	dB	
Transmitter Reflectance	Rt	-	-	-12	dBm	

Parameter	Symbol	Min	Typ	Max	Unit.	Note
Average Launch Power of OFF transmitter each lane	Poff	-	-	-30	dBm	
<b>Receiver</b>						
Rx Differential Output Amplitude	Vout p-p	350	-	900	mV	
Receiver Optical Wavelength	L0	1294.53	-	1296.59	nm	
	L1	1299.02	-	1301.09	nm	
	L2	1303.54	-	1305.63	nm	
	L3	1308.09	-	1310.19	nm	
Damage threshold	Rdam	5.5			dBm	
Average Receive Power, each lane	Pin	-20	-	-4.9	dBm	
Receiver Power, each lane		-	-	-4.9	dBm	
Receiver Sensitivity(OMA), each lane	Sen			-18.5	dBm	Note 1
LOS Assert Level	LOSA	-35	-	-	dBm	
LOS De-Assert Level	LOSD	-	-	-20	dBm	
LOS Hysteresis	LOSH	0.5			dB	

Notes:

1. Measured with a test pattern of PRBS 2<sup>31</sup>-1 at Pre-fec BER 5E-5.

#### 4. Digital Diagnostic Functions

Parameter	Symbol	Min.	Max.	Unit	Notes
Temperature	DDMI_Temp	-3	3	°C	1LSB=1/256°C
Supply Voltage	DDMI_Vcc	-3%	3%	V	1LSB=0.1mV
Bias Current	DDMI_Ibias	-10%	10%	mA	1LSB=2uA
TX Optical Power	DDMI_TX	-3	+3	dB	1LSB=0.1uW
RX Optical Power	DDMI_RX	-3	+3	dB	1LSB=0.1uW

## 5. PIN DIAGRAM

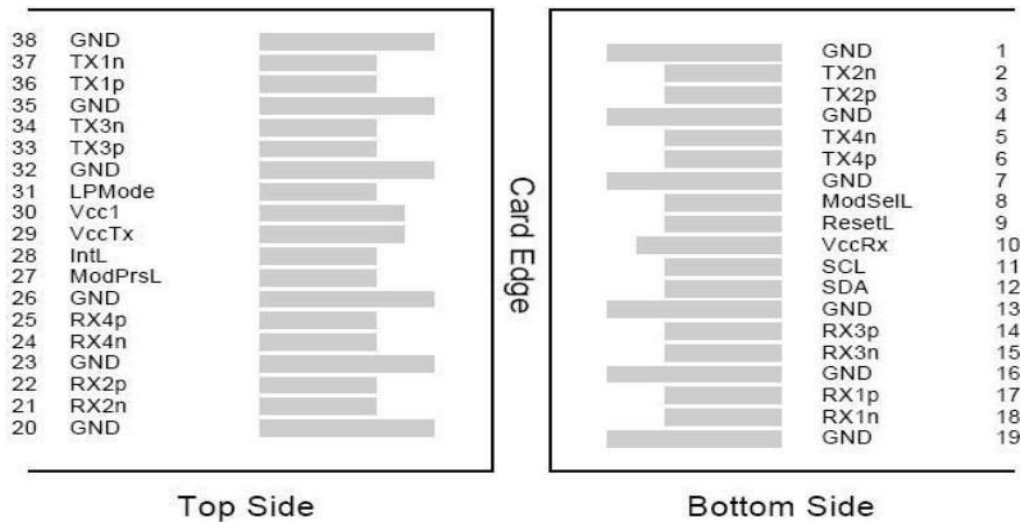

## 6. PIN DESCRIPTIONS

Pin	Logic	Symbol	Name/Description	Notes
1		GND	Transmitter Ground (Common with Receiver Ground)	1
2	CML-I	Tx2n	Transmitter Inverted Data Input	
3	CML-I	Tx2p	Transmitter Non-Inverted Data output	
4		GND	Transmitter Ground (Common with Receiver Ground)	1
5	CML-I	Tx4n	Transmitter Inverted Data Input	
6	CML-I	Tx4p	Transmitter Non-Inverted Data output	
7		GND	Transmitter Ground (Common with Receiver Ground)	1
8	LVTTL-I	ModSelL	Module Select	2
9	LVTTL-I	ResetL	Module Reset	2
10		VccRx	3.3V Power Supply Receiver	
11	LVC MOS-I/O	SCL	2-Wire serial Interface Clock	2
12	LVC MOS-I/O	SDA	2-Wire serial Interface Data	2
13		GND	Transmitter Ground (Common with Receiver Ground)	1
14	CML-O	Rx3p	Receiver Non-Inverted Data Output	
15	CML-O	Rx3n	Receiver Inverted Data Output	
16		GND	Transmitter Ground (Common with Receiver Ground)	1
17	CML-O	Rx1p	Receiver Non-Inverted Data Output	
18	CML-O	Rx1n	Receiver Inverted Data Output	
19		GND	Transmitter Ground (Common with Receiver Ground)	1

20		GND	Transmitter Ground (Common with Receiver Ground)	1
21	CML-O	Rx2n	Receiver Inverted Data Output	
22	CML-O	Rx2p	Receiver Non-Inverted Data Output	
23		GND	Transmitter Ground (Common with Receiver Ground)	1
24	CML-O	Rx4n	Receiver Inverted Data Output	
25	CML-O	Rx4p	Receiver Non-Inverted Data Output	
26		GND	Transmitter Ground (Common with Receiver Ground)	1
27	LVTTTL-O	ModPrsl	Module Present	
28	LVTTTL-O	IntL	Interrupt	
29		VccTx	3.3V power supply transmitter	
30		Vcc1	3.3V power supply	
31	LVTTTL-I	LPMODE	Low Power Mode	2
32		GND	Transmitter Ground (Common with Receiver Ground)	1
33	CML-I	Tx3p	Transmitter Non-Inverted Data Input	
34	CML-I	Tx3n	Transmitter Inverted Data Output	
35		GND	Transmitter Ground (Common with Receiver Ground)	1
36	CML-I	Tx1p	Transmitter Non-Inverted Data Input	
37	CML-I	Tx1n	Transmitter Inverted Data Output	
38		GND	Transmitter Ground (Common with Receiver Ground)	1

Notes:

1. Module circuit ground is isolated from module chassis ground within the module.
2. Open collector should be pulled up with 4.7K to 10K ohms on host board to a voltage between 3.15V and 3.6V.

## 7. MECHANICAL SPECIFICATION

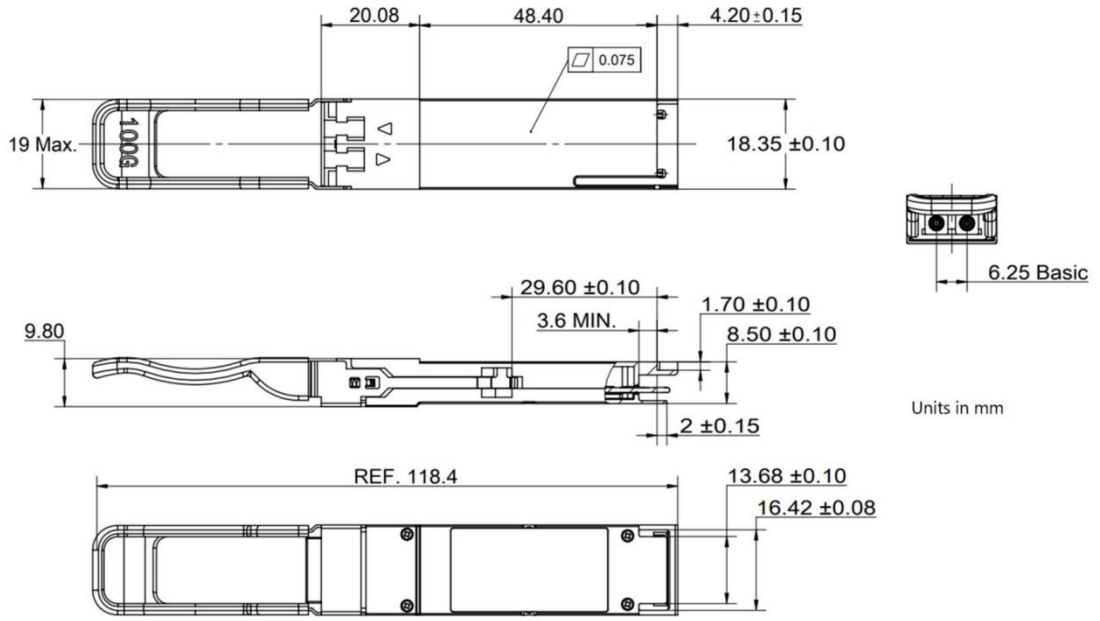

## 8. LABEL DIAGRAM



**TQ13L2E-CN**

QSFP28 100G Duplex 30km ER4 LC

Class 1 Laser  
MADE IN CHINA



X.XX.XX.XXX

S/N: ??????????

